

We touch your **electricity** everyday!

WiNtrip

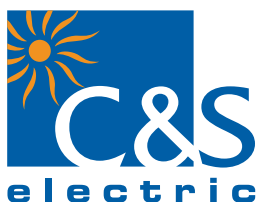

**Final Distribution
Products**

WiNtrip Final Distribution Products

C&S Electric Ltd. is amongst the leading suppliers of electrical equipment in India and is India's largest exporter of industrial switchgear. It's wide range of electrical and electronic products find application in power generation, distribution, control, protection and final consumption.





WiNtrip

Residual Current Circuit Breaker

From Bungalows to High Risers, from Trade Centres to Hotels, from Clinics to Hospitals, from escalators to elevators electricity is the foremost requirement. Electricity has become an integral part of our life so common to our daily requirements that we forget its intricacies and hazardous behaviour.





Day after day we come across many un to do events hampering human lives due to negligent usage of electricity. Even large number of Industrial and Domestic fire are attributed to and caused by electricity.

Faulty insulated equipments or wrong usage of electrical devices cause current to flow through insulation to the earth. This is leakage current. This current poses two severe risk factors which are

- Fire Risk
- Electrocutation Risk

Residual Current Circuit Breaker provides the function of isolation switching and earth leakage protection of electrical circuits. It also provides the indirect protection of the human body against the dangerous effects of electric current. It is also a protective device against fire caused by the electrical circuit fault.

Physiological Effect of Electric Current on Human Body

500 mA		Immediate cardiac arrest resulting in death
70-100 mA		Cardiac fibrillation; the heart begins to vibrate and no longer beats at a steady rate. This situation is dangerous since it is irreversible
20-30 mA		Muscle contraction can cause respiratory paralysis
10 mA		Muscle contraction : the person remains "stuck" to the conductor
1-10 mA		Prickling sensations

As per Indian Electricity Rules 1956 at all installations with load above 5 KW use of RCCB is compulsory



IS/IEC 12640-1:2008



CM/L-3148552



RoHS
Compliant

Highlights

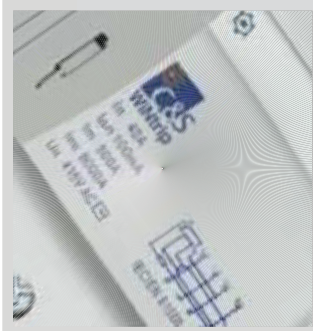

A state-of-the-art product fit for Industrial, Residential and Commercial applications.

It is one piece residual current circuit breaker which is used both for control and isolation of electrical circuits. It provides total protection to all living beings against direct and indirect contact as well as to installations, big or small, against insulation faults. **Human life is valueless and WiNtrip RCCB is the solution provider for safeguarding it.**

Majority of mishaps occur due to current leakage consequently leading to fire. WiNtrip RCCB of the required rating instantly detects this leakage and terminates the supply reducing the risk of any kind of fire. The range is available in AC Residual Tripping Characteristics in 2 & 4 Pole configurations in 16, 20, 25, 32, 40, 63, 80 & 100Amps in 30, 100 & 300mA sensitivity.

- Provides protection against earth fault/leakage current and also fulfill the function of isolation.
- Automatically measures and disconnect the circuit when earth fault/leakage current occurs and exceeds the rated sensitivity.
- High short-circuit current withstand capacity - 6kA
- Dual termination possible for cable and comb type busbar connection
- Equipped with finger protected connection terminals (Ip20)
- Fire resistant plastic parts to withstand abnormal heating and strong impact
- Independent of power supply and line voltage. Also free from external voltage fluctuation.
- Incorporates a filtering device for prevention of nuisance tripping due to transient voltage
- Easy padlocking facility.



Technical Data - Characteristics

Standards			IS 12640-1:2008
Residual tripping characteristics			AC
Tripping time at $I_{\Delta n}$	Instantaneous	ms	<40
	Selective	ms	>150
Rated current		A	16, 20, 25, 32, 40, 63, 80 & 100
Rated residual current $I_{\Delta n}$		mA	30, 100, 300
Calibration temperature		°C	30
Number of poles versus modules			1
Rated voltage U_n	2P AC	V	240
	4P AC	V	415
Frequency		Hz	50/60
Maximum service voltage U_{bmax}		V	2P=265 / 4P=455
Minimum service voltage U_{bmin}		V	2P=100 / 4P=190
Power supply			Top / Bottom
Rated making and breaking capacity (I_m)		A	500 (or 10x I_n)
Residual making and breaking capacity ($I_{\Delta m}$)		A	500 (or 10x I_n)
Conditional short-circuit capacity (I_{nc})		A	6000 Fuse 100A gLgG
Conditional residual short-circuit capacity ($I_{\Delta c}$)		A	6000 Fuse 100A gLgG
Grid distance (safety distance between two devices)		mm	35
Isolator application			yes
Insulation degree	Insulation voltage	V (DC)	660
	Shock voltage (1.2/50 μ s)	kV	6
	Insulation resistance	m Ω	1000
	Dielectric strength	V	2500
Shock resistance (in x, y, z direction) (EN / IEC 60077/16.3)		40g	18 shocks 5 ms
Vibration resistance (in x, y, z direction; EN / IEC 60068-2-6)		1.5g	30 min, 0~80Hz
Endurance	electrical at U_n, I_n		10000
	mechanical at U_n, I_n		20000
Protection degree (outside/inside electrical enclosure) with door			IP20 / IP40
Self extinguish degree (according to UI94)			V2
Tropicalisation (acc. to EN/IEC 60068-2, DIN 40046)		°C/RH	+55 / 95%
Pollution degree (acc. EN/IEC 60947-1)			3
Operating temperature			AC (-5 ~ +60)
Storage temperature		°C	-25 ~ +70
Terminals capacity	Rigid cable min/max (top)	mm ²	1.5/25
	Flexible cable min*/max (top)	mm ²	1.5/25
	Rigid cable min/max (bottom)	mm ²	1.5/25
	Flexible cable min*/max (bottom)	mm ²	1.5/25
	(*Flexible cable 0.75/1/1.5 mm ² with cable lug)		
Busbars systems	Pin		yes
	Fork		yes
CE marking			yes
Torque	Top / Bottom	Nm	5/5



Test Button



Rated current I_n / $I_{\Delta n}$



DIN Rail Mounting

Type AC		
Rated Current setting I_n	A	16, 20, 25, 32, 40, 63, 80, 100
Residual current $I_{\Delta n}$	mA	30, 100, 300
Rated voltage AC U_n	V	2P : 240; 4P : 415
Minimum operating voltage U_{min}	V	2P : 100; 4P : 190
Mechanical/electrical endurance		20000 / 10000
Tropicalisation acc.to EN/IEC 60068-2-28/2-30 and DIN 40046		95% RH at 55 °C
Terminal capacity exible/rigid cable	mm ²	25/25
Poles		2, 4
Nuisance tripping resistance		250A 8/20us; 200A 0.5us - 100kHz
Ambient temperature	°C	-5 upto 40
Weight	g	2P- 224.5; 4P-409

Short-circuit Capacity	
Acc. to EN/IEC 61008-1	$I_m = 500A$
Making and breaking capacity	$I_{Dm} > 500A$ from 16 upto 40A $I_{Dm} = 10I_n$ from 63 upto 100A
Short-circuit capacity	$I_{nc} = 6000A$ at 240/415V Fuse 80A gG

Normal operation and mounting requirement

1. Ambient temperature $-5^{\circ}C \sim +40^{\circ}C$ •Altitude above sea level less than 2000 m.
2. Humidity not exceeding 50% at $40^{\circ}C$ and not exceeding 90% at $25^{\circ}C$.
3. Installation class II or III.
4. Pollution degree 3.
5. All equipments used should be properly earthed.
6. For right operation should ensure that the neutral conductor on the load side of the RCCB must not be linked to earth. Otherwise tripping may be impaired or nuisance tripping may occur.
7. Installation method DIN Rail mounting type.
8. Product should be installed vertically at the place where there shall be no severe impact and vibration.
9. The product is switched on when the handle is at upper position.

RCCB Tripping Cause Detection & Remedy

1. Switch OFF all the MCBs connected to the circuit downstream the RCCB.
2. Switch ON the RCCB and switch ON the MCBs one by one.
3. During switching ON of a particular circuit RCCB keeps tripping frequently.
4. In this circuit the fault persists.
5. Isolate the faulty circuit, correct the fault. Now the RCCB will not trip.

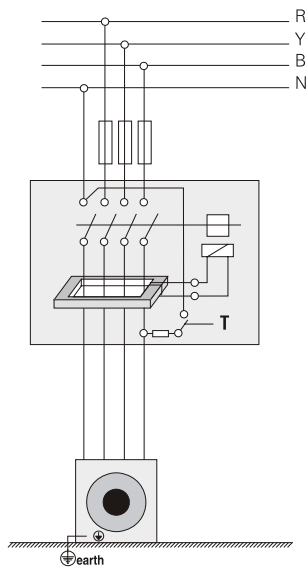

Working Principle

The RCCB works on the current balance principle. The supply conductors are passed through a toroid and form the primary windings of a current transformer. Its secondary winding is connected to a highly sensitive electromagnetic trip relay, which operates the trip mechanism.

In a healthy circuit, sum of the current in phases, is equal to the current in the neutral and the vector sum of all current is equal to zero. If there is any insulation fault in the current and leakage current flows to earth, the current do not balance and their vector sum is not equal to zero. This imbalance is detected by the core balanced current transformer, the RCCB is tripped and supply to load is interrupted.

Sensitivity Selection Criteria

Sensitivity	Application
30mA	Designed for additional protection against direct contact. The 30 mA RCCB protects against leakage currents and indirect contact with earth loop impedance up to 1667 Ohms.
100mA	Is suitable for protection against indirect contact and leakage current for larger installations. The 100 mA RCCB's operate within 30 ms, but do not provide the same level of personal protection as the 30 mA units. The 100 mA RCCB protects against leakage currents and indirect contact with earth loop impedance up to 500 ohms.
300mA	A less sensitive protection device suitable for large installations having high levels of leakage current. 300 mA RCCB's protect against leakage current and indirect contact up to 167 ohms earth loop impedance.

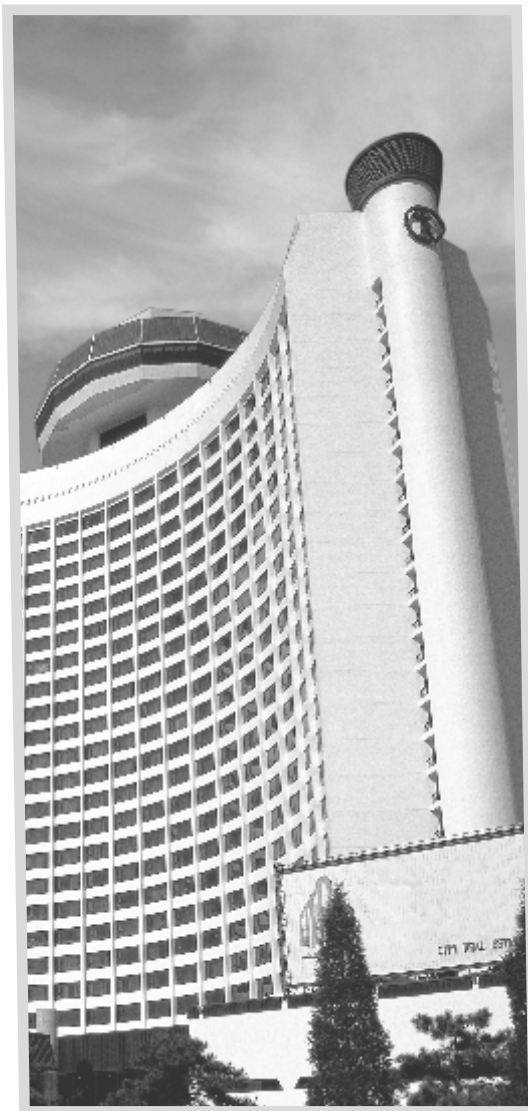

Current Limiting Curve

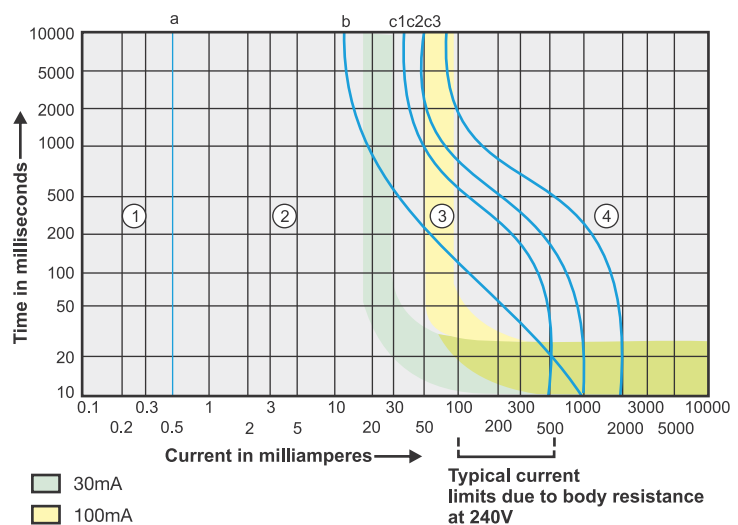

Product Reference - RCCB

Description	Wiring Diagram	Rated Current	Reference	Sensitivity
Double Pole		16	CSR2P16A30 CSR2P16A100 CSR2P16A300	30 100 300
		20	CSR2P20A30 CSR2P20A100 CSR2P20A300	30 100 300
		25	CSR2P25A30 CSR2P25A100 CSR2P25A300	30 100 300
		32	CSR2P32A30 CSR2P32A100 CSR2P32A300	30 100 300
		40	CSR2P40A30 CSR2P40A100 CSR2P40A300	30 100 300
		63	CSR2P63A30 CSR2P63A100 CSR2P63A300	30 100 300
		80	CSR2P80A30 CSR2P80A100 CSR2P80A300	30 100 300
		100	CSR2P100A30 CSR2P100A100 CSR2P100A300	30 100 300
		Four Pole		16
20	CSR4P20A30 CSR4P20A100 CSR4P20A300			30 100 300
25	CSR4P25A30 CSR4P25A100 CSR4P25A300			30 100 300
32	CSR4P32A30 CSR4P32A100 CSR4P32A300			30 100 300
40	CSR4P40A30 CSR4P40A100 CSR4P40A300			30 100 300
63	CSR4P63A30 CSR4P63A100 CSR4P63A300			30 100 300
80	CSR4P80A30 CSR4P80A100 CSR4P80A300			30 100 300
100	CSR4P100A30 CSR4P100A100 CSR4P100A300			30 100 300

Dimensions

Double Pole

CSRB2P16A30	CSRB2P40A30
CSRB2P16A100	CSRB2P40A100
CSRB2P16A300	CSRB2P40A300

CSRB2P20A30	CSRB2P63A30
CSRB2P20A100	CSRB2P63A100
CSRB2P20A300	CSRB2P63A300

CSRB2P25A30	CSRB2P80A30
CSRB2P25A100	CSRB2P80A100
CSRB2P25A300	CSRB2P80A300

CSRB2P32A30	CSRB2P100A30
CSRB2P32A100	CSRB2P100A100
CSRB2P32A300	CSRB2P100A300

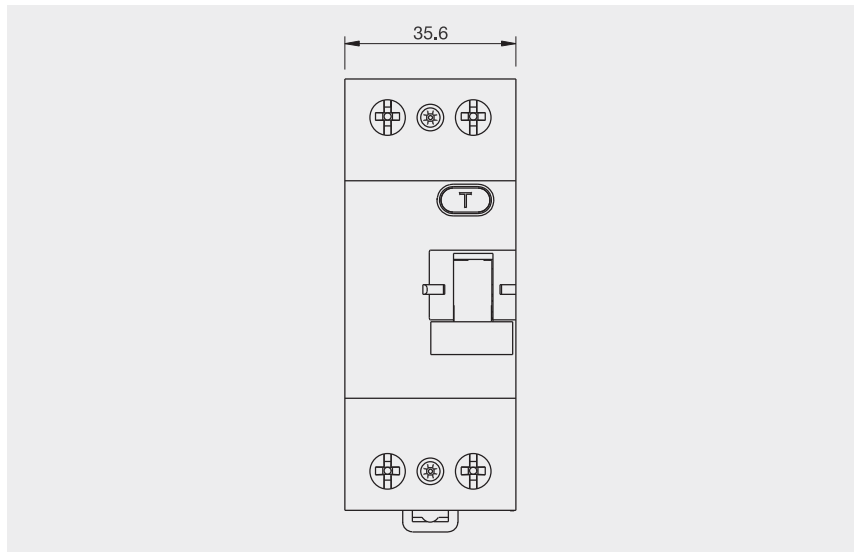

Four Pole

CSRB4P16A30	CSRB4P40A30
CSRB4P16A100	CSRB4P40A100
CSRB4P16A300	CSRB4P40A300

CSRB4P20A30	CSRB4P63A30
CSRB4P20A100	CSRB4P63A100
CSRB4P20A300	CSRB4P63A300

CSRB4P25A30	CSRB4P80A30
CSRB4P25A100	CSRB4P80A100
CSRB4P25A300	CSRB4P80A300

CSRB4P32A30	CSRB4P100A30
CSRB4P32A100	CSRB4P100A100
CSRB4P32A300	CSRB4P100A300

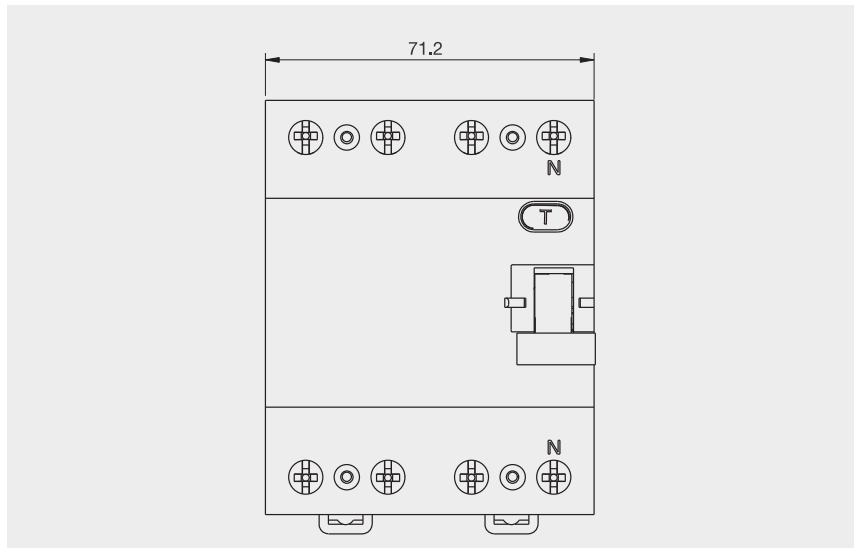

Side view - Double & Four Pole

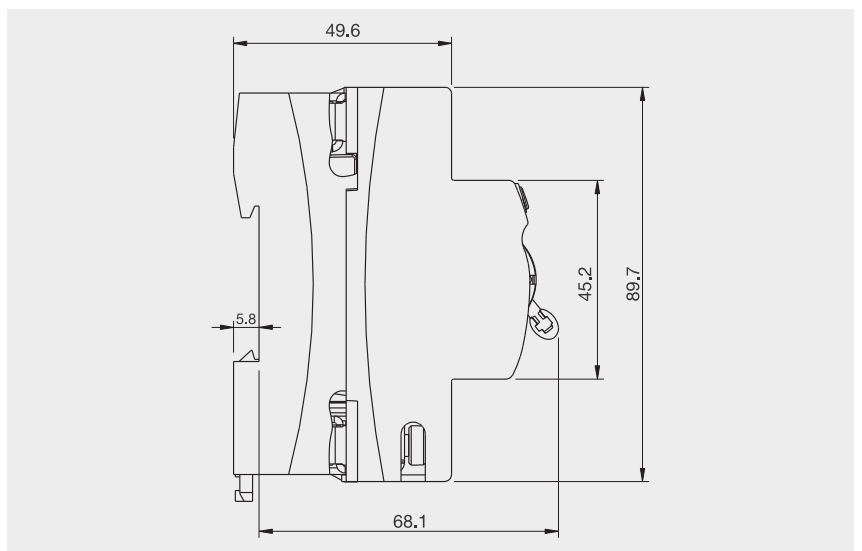

All dimensions are in mm

Introduction - Distribution Board

